

digital technology



Index

1. Introduction	page 2
2. Installation of decoder, speaker- and electrical couplers	
2.1 Decoder installation	page 3
2.2 Speaker installation	page 4
2.3 Installation of electrical couplers	page 5
3. Function output mapping	page 6
3.1 NEXT18S - interface	page 6
3.1.1 NEXT18S - function outputs	page 6
3.1.2 NEXT18S - function button mapping	page 6
3.2 ECU (Electronic Control Unit / slave decoder)	page 7
3.2.1 ECU function outputs	page 7
3.2.2 ECU function button attribution	page 8
4. ECU CV – programming	page 9
4.1 Function mapping (Aspects)	page 10
4.1.1 Normal function mapping	page 10
4.1.2 Output Bit mask	page 10
4.1.3 Extended function mapping	page 10
4.1.4 Default factory configured Aspect overview	page 11
4.1.5 Example of function mapping settings	page 12
4.2 Effects for function outputs	
4.2.1 Light intensity	page 13
4.2.2 Fade effect	page 13
4.2.3 Delayed ON and OFF outputs switching	page 13
4.3 Electrical Couplers (AUX12/13)	page 14
4.4 SPP operation	page 15
4.5 DC operation	page 15
4.6 Short circuit protection	page 15
4.7 CV table	page 16

1. Introduction

Congratulations for the purchase of a TILLIG quality modell. We are giving you all the information you need to convert your loco to digital and adjust all the fatures as you want.

Our modell of loco BR132 offer you the following functions:

- Driving direction-dependented 3-light front signal
- Driving direction-dependented 1-light front signal
- Independently switchable rear light
- Shunting light in 3 different variants
- High beam at the upper light
- Front and rear drivers cab light independently switchable
- Integrated powercap
- Sound installation ready via NEXT18S
- 2 digital couplers installation ready



For Plug and Play you can use our **decoder item no. 66039** (train-O-matic). The decoder is completly programmed to use all functions of this modell (*excepting sound*).

If you want to **install sound**, you can use any SUSI bus-capable Next18 sound decoder. The required **loudspeaker**, including wires, is available under **item no. 66057**.

On each page of this manual, you will find the hardware-software index at the bottom left. This shows the development status of the PCBs and the software of the ECU.

To make sure that you have the right variant, you can take a look at the operating instructions enclosed with the product. There you will find the spare parts list. The PCB on which the ECU is installed receives the HW-SW index. If this index does not exist, you can assume that it is HW01SW01.

In addition, the index is also stored in CV980.2 (hardware) and CV980.3 (software), as long as the slave address 3 (897=3).

Otherwise, CV940.2&3 for slave address=2 or CV900.2&3 for slave address=1 are to be used for reading (see table).

CV			Factory Default CV Values	Value-Range	Description
Slave1	Slave2	Slave3			
897			3	1-3	SUSI Slave Adress
900.2	940.2	980.2	1		TILLIG Hardware ID
900.3	940.3	980.3	1		TILLIG Software ID

At the bottom right you will find the date of the last modification of the manual.

2. Installation of decoder, speaker- and electrical couplers

2.1 Decoder installation

Step 1:

To install a decoder, you have to **remove the upper part**. To do this, spread it in the area of the bogies and pull it off the die-cast frame upwards.

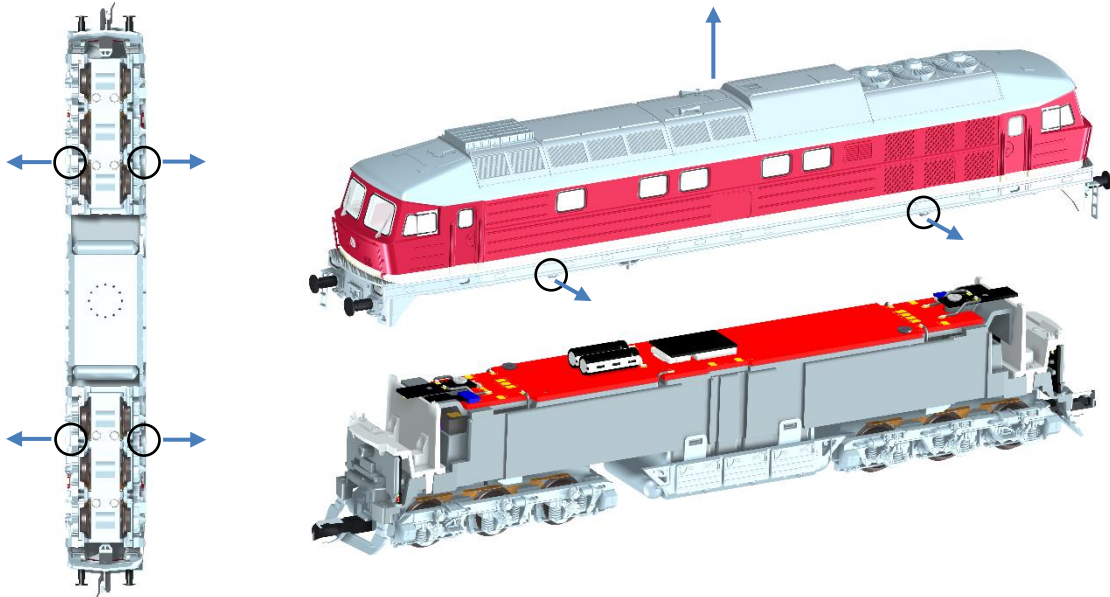

Step 2:

Then remove the **redisturb PCB** and replace it with your **Next18 decoder**.

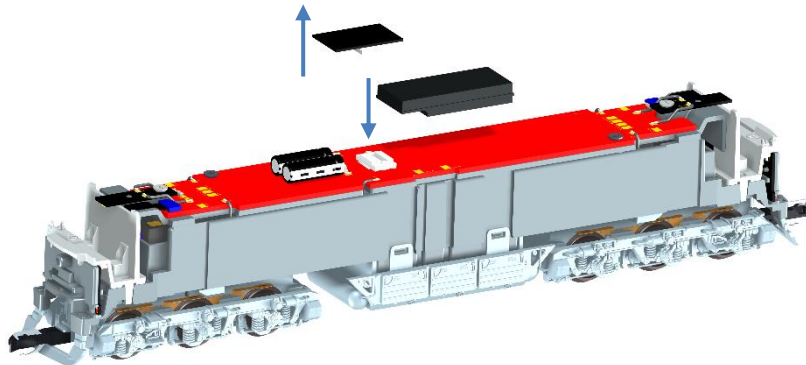

Step 3:

Finally, snap the top back on.

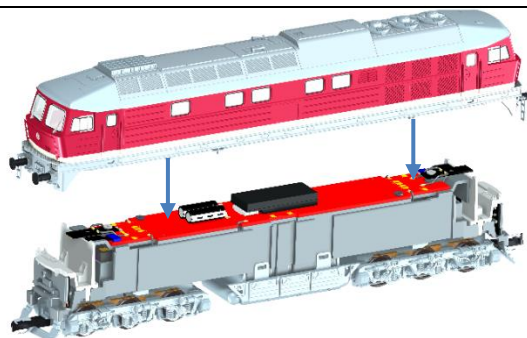

2.2 Speaker installation

Step 1:

To install a loudspeaker, you have to **remove the top part** first (see 2.1).

Step 2:

This is installed in the tank. To disassemble it, you must carefully remove its tabs from the snap-in lugs of the zinc frame and pull them off.



Step 3:

Solder the wires according to the illustration.

The loudspeaker incl. wires is available under the **item no. 66057**.

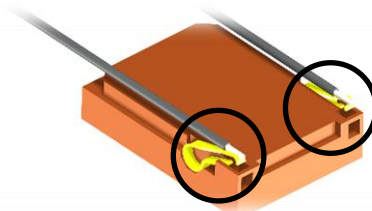

Step 4:

Glue the speaker to the die cast frame.

Please note that the solder points must not be in contact with the frame, otherwise this may lead to the destruction of the speaker and/or decoder. To glue in the speaker, remove the carrier foil and insert it according to the illustration.

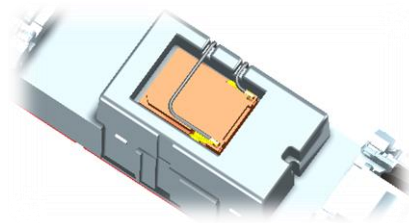

Step 5:

Then **solder the wires to the PCB** and place them in the wire guide so that they do not protrude over the die-cast frame.

Now **mount the tank**. Finally, **snap the top part back on**.

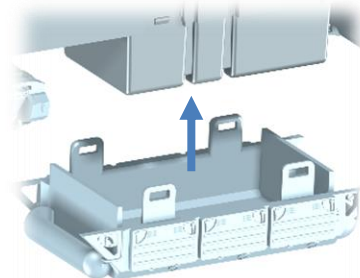
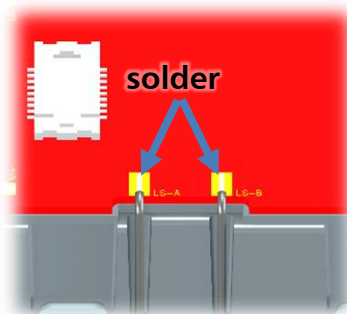

2.3 Installation of electrical couplers

Step 1:

For the installation of electrical couplings, the **upper part must first be removed** (see 2.1). The following description refers to the installation at the front. The installation is done in the same way at the rear.

Step 2:

Now the **TILLIG coupling and the driver's cab imitation must be removed**. To disassemble the cab imitation, **loosen the screw of the cab lighting and fold it away to the rear**.

Then **pull the cab imitation upwards from the die-cast frame**.

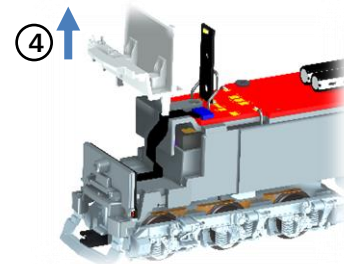
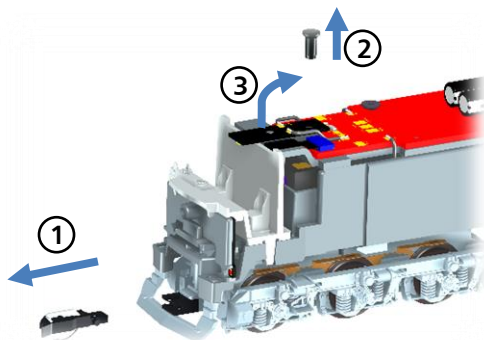

Step 3:

Next, the **wires of the electrical coupling have to be laid**. These must first be **routed from below through the opening in the die-cast frame** and then through the slots to the left and right below the light guide plate.

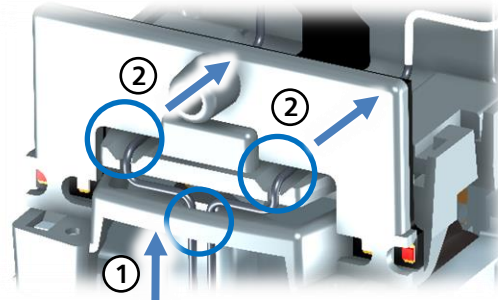

Step 4:

Now the **driver's cab imitation and the driver's cab lighting have to be reinstalled**. The coupling can then also be **plugged in** and the wires finally **straightened**. **Make sure that the coupling still can swing out fully**.

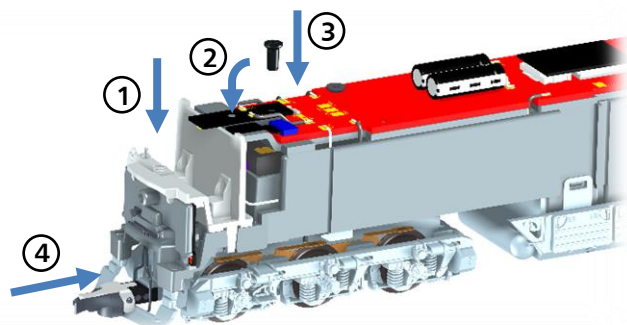

Step 5:

Solder the wires to the solder pads of AUX12 (front) or AUX13 (rear) and VCC according to the instructions of your coupling. example SD-Modell: white mark to VCC

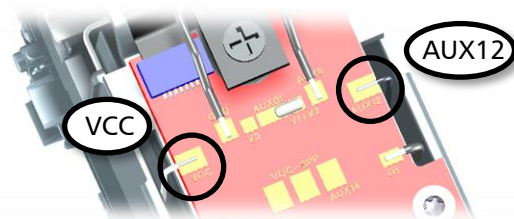

Step 6:

Finally, **snap the top back on**.

3. Function output mapping

When using a third-party NEXT18 decoder, the function key assignment and the SUSI communication must be programmed by yourself (see 3.1.2). If you use a different NEXT18 decoder of your own choice, you will have to program the function button mapping (assignment) and turn on the SUSI interface bus by yourself.

3.1 NEXT18S – decoder

This model is using a NEXT18 interface.

The decoder functions are designed by NEM662/RCN118 – NEXT18S.

3.1.1 NEXT18S – function outputs

<p>FL (AUX0f) – frontlight forwards</p>	<p>RL (AUX0r) – frontlight backwards</p>
<p>AUX1 red light front</p>	<p>AUX2 red light back</p>
<p>AUX3 (SUSI bus – clock) and AUX4 (SUSI bus – data) are used for communication between the decoder and the ECU (On Board). In most cases you must first program the decoder for enabling the SUSI interface bus.</p> <p>AUX5 (LS-A) and AUX6 (LS-B) are reserved for the loudspeaker.</p>	

3.1.2 NEXT18S – function button mapping

The function button mapping listed here correspond to the pre-programmed TILLIG decoder **item no. 66039**. If you do not want to change the mapping of the ECU, we recommend to using it for third-party decoders as well.

Note 1: In order to use the light switch-off 2 (AUX11; see 3.2.1) as a shunting light (front and back side ON), the following setting must be made in the TILLIG decoder 66039: **AUX0 with F7 on both sides (AUX0f+r ON): CV42=3**

Note 2: When using **third-party decoders**, **AUX0f+r ON** must also be programmed/mapped for the

function of the shunting light (front and back side ON) at **F2** (bottom right) and/or **F7** (bottom left). To do this, follow the operating instructions of your decoder.

F0 (F2 off)	Front light, driving direction-dependent
F1 (F2 off)	Rear light, driving direction-dependent
F0+F2	Shunting light downright
F3	Shunting gear
F12	Electical decoupling driving direction-dependented (without function output attribution)

3.2 ECU (Electronic Control Unit / slave decoder)





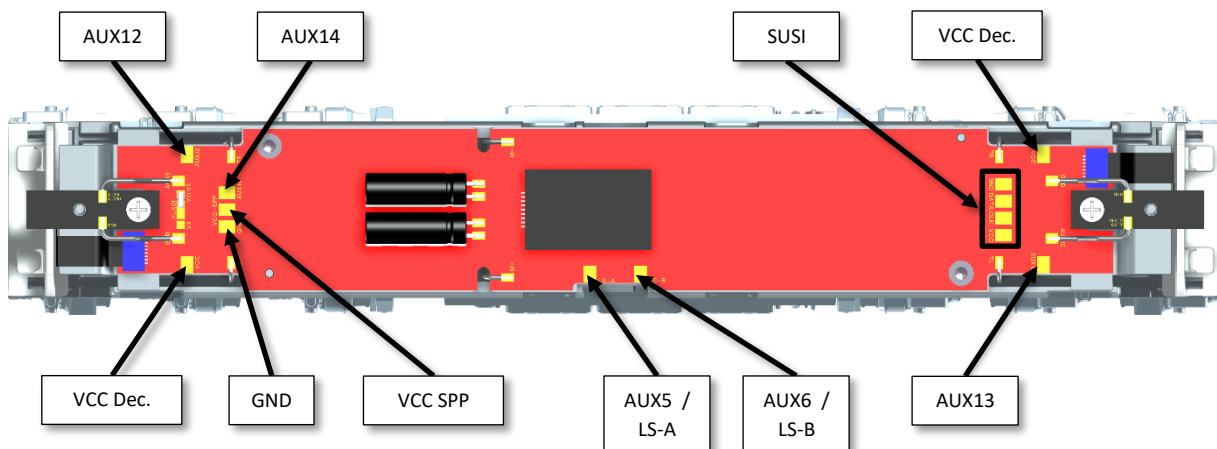
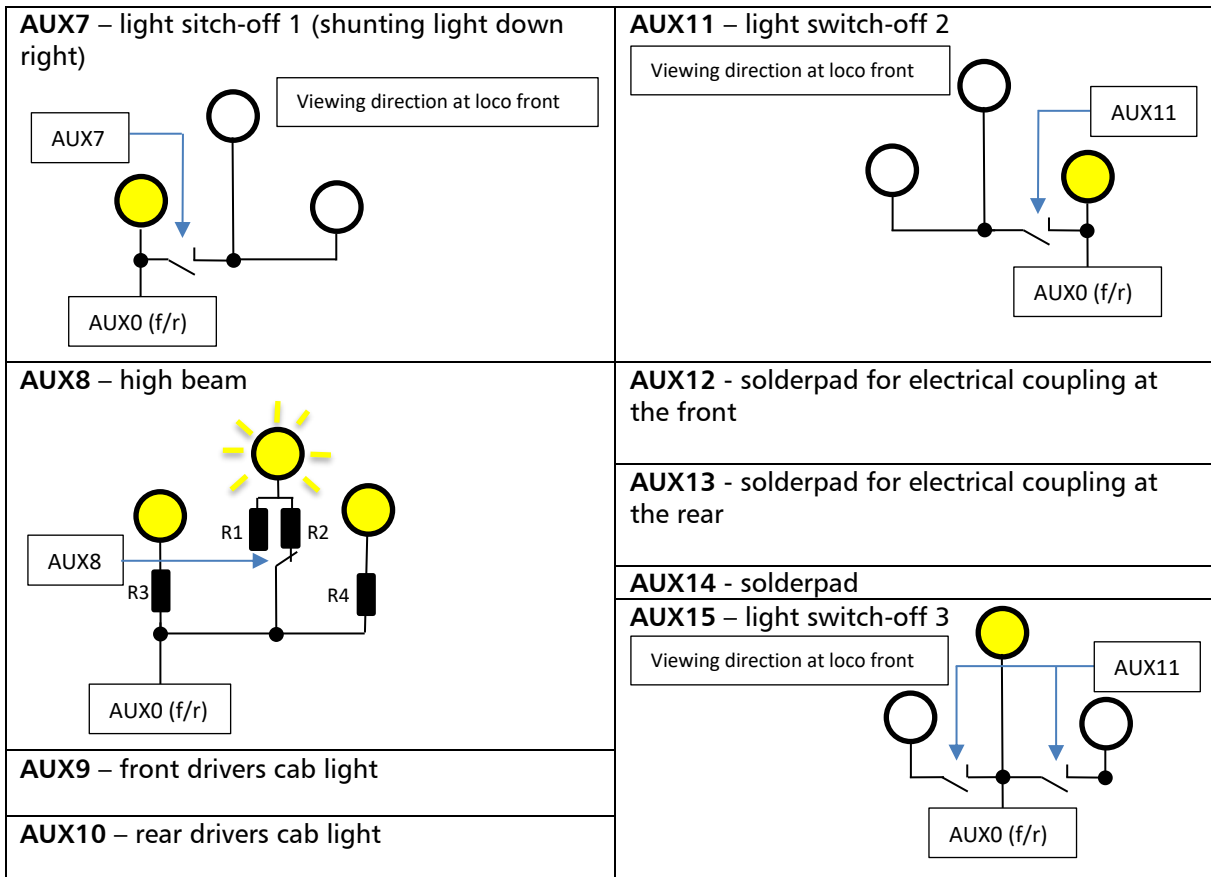

Some functions are controlled by the ECU, which is a function decoder integrated on the locomotive main circuit board. The ECU is communicating with the Next18 decoder on the standard SUSI bus on the AUX3 and AUX4 outputs of the decoder. To enable the SUSI communication, the Next18 decoder should be configured accordingly. All function outputs are amplified to 500mA.

3.2.1. ECU function outputs



!Important! VCC SPP = continuous positive voltage buffered, 8,2 Volt
 VCC Dec. = continuous positive voltage from decoder

3.2.2 ECU function button attribution

F2 (+F0)	light switch-off 1 frontlight bottom right	
F4 (+F0)	high beam	 
F5	front drivers cab light	
F6	rear drivers cab light	
F7 (+F0)	light switch-off 2 frontlight bottom left	
F4+F7 (+F0)	Light switch-off 1+2 frontlight bottom left and right	
F12	Coupling function front/rear (driving direction-dependent)	
F13	AUX14	
F14 (+F0)	light switch-off 3 top front light	
F4+F14 (+F0)	High beam + light switch-off 3	

4. ECU CV – programming

According to the SUSI standard (RCN-600) the CV-s (Configuration Variables) of the ECU are organized in groups of 40 CVs. The 40 CVs are addressable in one Bank. The Bank contains the group of 40 CVs present 3 times numerated continuously. To each SUSI slave Address, direct access to a group of 40 CVs is possible.

The CV range CV900-CV939 is dedicated to the slave address 1,

CV940 to CV979 for the slave address 2

and CV980 to CV1019 to slave address 3.

The ECU is using the slave address 3 by default, so in the factory configuration all of the configurations CVs are used in the range CV979-CV1019.

If you want to change the slave address, program the desired address into the CV897. If you change the slave address, the CV ranges will change by the value 40 per address jump (see above).

But since more than 40 CV's are needed, multiple Banks are available. In order to better represent the Banks after the CVs, a dot is used, as described in the RCN600. (e.g. 983.2 = CV983, Bank 2). The Banks can be selected between 0 and 254. Currently, Bank0, Bank1, Bank2, Bank3 and Bank254 are used for the ECU. The CV Bank Index is selected in CV1021 (which is accessible all the time). Before executing any CV operation, please check the Index of the CV Bank. The default value of CV1021 is 3 (Bank3).

Example1: CV900.0 means that CV900 is located in Bank0 for the SUSI slave address 1. The corresponding CV is CV940.0 for the SUSI slave address 2 or CV980.0 for the SUSI slave address 3.

Example2: CV904.2 means that CV904 is located in Bank2 for the SUSI slave address 1. The corresponding CV is CV944.2 for the SUSI slave address 2 or CV984.2 for the SUSI slave address 3.

Please note: All the following CVs are described for slave address 3.

The ECU is locked by delivery via the programming lock in CV982.3 and 983.3. In order to be able to program it, the ECU must be unlocked by writing both CV's to the same value, e.g. 0. To do this, the first thing to do is to write bank 3 in CV1021. After that, CV 982 and 983 can be written. Only then, you can will be able to change the other CV's.

(step1: CV1021=3; step2: CV982=0; step3: CV983=0)

We strongly recommend reactivating the programming lock after completing the programming, otherwise the ECU will be overwritten with a software update of your decoder and may no longer work!

(step1: CV1021=3; step2: CV982=0; step3: CV983=1)

To RESET the ECU to factory settings, write in the CV980.0=0.

We recommend that you change the CV values only if you are sure of their function and the impact of your action. Incorrect CV settings can negatively affect the performance of the ECU or cause incorrect responses to the commands transmitted from the command station.

4.1 Function mapping (Aspects)

The F0-F28 function buttons mapping to the outputs AUX7-15 is made in a double level scheme. The group of outputs is controlled in the same time by a function is called Aspect. The ECU has a total 8 configurable Aspects.

4.1.1 standard function mapping

The standard function mapping is used by default (CV982.2=0). So only one function button can be defined for one aspect. The function buttons F0-F28 (value 0-28) can be selected. These are assigned to Aspect 1 (CV995.0) to Aspect 8 (CV1002.0) with their value. If no function key is to be assigned, a value from 29 till 63 must be written.

CV1004.0-1019.0 (Aspect 1-8) describes which function outputs from AUX7 to AUX14 and CV1004.1-1019.1 (Aspect 1-8) which function outputs are used from AUX15 to AUX22. The even CV-numbers are for the forward direction and the odd numbers for reverse direction. These CVs are described after the following Bit mask.

4.1.2 Output Bit mask

Each bit position corresponds to one output as it can be seen in the table below:

Bit	Bit7 (= 128)	Bit6 (= 64)	Bit5 (= 32)	Bit4 (= 16)	Bit3 (= 8)	Bit2 (= 4)	Bit1 (= 2)	Bit0 (= 1)
AUX7-14	AUX14	AUX13	AUX12	AUX11	AUX10	AUX9	AUX8	AUX7
AUX15-22	/	/	/	/	/	/	/	AUX15

4.1.1 extended function mapping

If one function button per Aspect is not enough for you, you can activate and use the extended function mapping. To do this, program CV982.2=1.

The extended function mapping allows you to assign up to 3 function buttons to each Aspect. There are 3 CV's assigned to each aspect, which looks like this for example for aspect 1: 1. Function button=CV995.0; 2. Function button=CV995.1; 3. Function button=C995.2 The keys F0-28 (value 0-28) can be assigned to these CV's.

By default, the first and second function button are setted as an OR-function, the third function button serves as a NOT-function (switch-off).

You can change this setting in the respective CV of the function button assignment as follows:

Bit 7 (value 128) constitutes the **AND-function** (e.g. F1 AND F2) and must be assigned to at least 2 function keys, which have to switched ON together to activate the function.

Bit 6 (value 64) is the **switch-off-function** (negation/NAND) (e.g. F1 AND-NOT F2, means as long as F2 is active, the Aspect remains switched off, regardless of whether F1 is activated or not). **This has not to be setted for the third Function button, because it's hard-programmed for it.**

If neither of the two bits is set, it is automatically the **OR-function** (e.g. F1 OR F2).

4.1.4 Default factory configured Aspect overview

Aspect1: F5 controls AUX9 (front drivers cab lightning).

-	AUX7-14	for Driving direction FWD	„AUX9“ defined in	CV1004.0=4
-	AUX15-22	for Driving direction FWD	„non“ defined in	CV1004.1=0
-	AUX7-14	for Driving direction BWD	„AUX9“ defined in	CV1005.0=4
-	AUX15-22	for Driving direction BWD	„non“ defined in	CV1005.1=0
-	1. Function button		„F5“ defined in	CV995.0=5
-	2. Function button (extended Mapping)		„non“ defined in	CV995.1=63
-	3. Function button (extended Mapping)		„non“ defined in	CV995.2=163

Aspect2: F6 controls AUX10 (back drivers cab lightning).

-	AUX7-14	for Driving direction FWD	„AUX10“ defined in	CV1006.0=8
-	AUX15-22	for Driving direction FWD	„non“ defined in	CV1006.1=0
-	AUX7-14	for Driving direction BWD	„AUX10“ defined in	CV1007.0=8
-	AUX15-22	for Driving direction BWD	„non“ defined in	CV1007.1=0
-	1. Function button		„F6“ defined in	CV996.0=6
-	2. Function button (extended Mapping)		„non“ defined in	CV996.1=63
-	3. Function button (extended Mapping)		„non“ defined in	CV996.2=63

Aspect3: F13 controls AUX14.

-	AUX7-14	for Driving direction FWD	„AUX14“ defined in	CV1008.0=128
-	AUX15-22	for Driving direction FWD	„non“ defined in	CV1008.1=0
-	AUX7-14	for Driving direction BWD	„AUX14“ defined in	CV1009.0=128
-	AUX15-22	for Driving direction BWD	„non“ defined in	CV1009.1=0
-	1. Function button		„F13“ defined in	CV997.0=13
-	2. Function button (extended Mapping)		„non“ defined in	CV997.1=63
-	3. Function button (extended Mapping)		„non“ defined in	CV997.2=63

Aspect4: F7 controls AUX11 (Light switch-off 2).

-	AUX7-14	for Driving direction FWD	„AUX11“ defined in	CV1010.0=16
-	AUX15-22	for Driving direction FWD	„non“ defined in	CV1010.1=0
-	AUX7-14	for Driving direction BWD	„AUX11“ defined in	CV1011.0=16
-	AUX15-22	for Driving direction BWD	„non“ defined in	CV1011.1=0
-	1. Function button		„F7“ defined in	CV998.0=7
-	2. Function button (extended Mapping)		„non“ defined in	CV998.1=63
-	3. Function button (extended Mapping)		„non“ defined in	CV998.2=63

Aspect5: F4 controls AUX8 (high beam).

-	AUX7-14	for Driving direction FWD	„AUX8“ defined in	CV1012.0=2
-	AUX15-22	for Driving direction FWD	„non“ defined in	CV1012.1=0
-	AUX7-14	for Driving direction BWD	„AUX8“ defined in	CV1013.0=2
-	AUX15-22	for Driving direction BWD	„non“ defined in	CV1013.1=0
-	1. Function button		„F4“ defined in	CV999.0=4
-	2. Function button (extended Mapping)		„non“ defined in	CV999.1=63
-	3. Function button (extended Mapping)		„non“ defined in	CV999.2=63

Aspect6: F2 controls AUX7 (Light switch-off 1)

- AUX7-14 for **Driving direction FWD** „AUX7“ defined in CV1014.0=1
- AUX15-22 for Driving direction FWD „non“ defined in CV1014.1=0
- AUX7-14 for **Driving direction BWD** „AUX7“ defined in CV1015.0=1
- AUX15-22 for Driving direction BWD „non“ defined in CV1015.1=0
- **1. Function button** „F2“ defined in CV1000.0=2
- 2. Function button (**extended Mapping**) „non“ defined in CV1000.1=63
- 3. Function button (**extended Mapping**) „non“ defined in CV1000.2=63

Aspect7: F12 controls AUX12 und AUX13 (Electrical couplings) driving directions depended.

- AUX7-14 for **Driving direction FWD** „AUX13“ defined in CV1016.0=64
- AUX15-22 for Driving direction FWD „non“ defined in CV1016.1=0
- AUX7-14 for **Driving direction BWD** „AUX12“ defined in CV1017.0=32
- AUX15-22 for Driving direction BWD „non“ defined in CV1017.1=0
- **1. Function button** „F12“ defined in CV1001.0=12
- 2. Function button (**extended Mapping**) „non“ defined in CV1001.1=63
- 3. Function button (**extended Mapping**) „non“ defined in CV1001.2=63

Aspect8: F14 controls AUX15 (Light switch-off 3)

- AUX7-14 for Driving direction FWD „non“ defined in CV1018.0=0
- AUX15-22 for **Driving direction FWD** „AUX15“ defined in CV1018.1=1
- AUX7-14 for Driving direction BWD „non“ defined in CV1019.0=0
- AUX15-22 for **Driving direction BWD** „AUX15“ defined in CV1019.1=1
- **1. Function button** „F14“ defined in CV1002.0=14
- 2. Function button (**extended Mapping**) „non“ defined in CV1002.1=63
- 3. Function button (**extended Mapping**) „non“ defined in CV1002.2=63

4.1.5 Example of function mapping settings

To configure Function F9 to turn on cabin front lights together with AUX11 in forward direction, and the cabin rear lights together with AUX14 in reverse direction using Aspect8 (available for user configuration) the following is to be done:

- Write in CV1002.0 the value 9 - this means that the Function F9 will control the Aspect8.
- For the forward direction - set Bit2 (AUX9) and Bit4 (AUX11) in CV1018.0. Decimal value will be 20.
- For the reverse direction - set Bit3 (AUX10) and Bit7 (AUX14) in CV1019.0. Decimal value will be 136.

4.2 Effects for function outputs

4.2.1 Light intensity

The PWM values of the outputs (light intensity) can be set in CV985.0 – CV990.0 (AUX7-AUX14) (see 4.7 CV table). If the outputs are used internally by the electronics of the ECU, so are used as light switch-off (e.g. shunting light), the outputs are not using the PWM values. Changing these PWM CV values has no effect on these.

4.2.2 Fade effect

The Fade effect setting can be activated in CV994.0. This CV is using the output bit mask (4.1.1.) By default the Fade effect is disabled for AUX7, 8, 11 and 15 since it is as an internal output. For programming the time values (8ms steps) please use CV983.0 (Fade in) and CV984.0 (Fade out).

4.2.3 Delayed ON and OFF outputs switching

The delayed switching (ON and OFF) can be controlled individually for each output of the ECU. The delay values (ON and OFF) will be valid globally for all outputs. The CV983.2 and 984.2 are using the same bitmask structure as in the table above. These two CV's are used for the delayed turn ON (CV983.2) and delayed turn OFF (CV984.2) of the specific AUX. The delay is active for an AUX output only if the corresponding bit is set (value 1) in the bitmask. By default the corresponding bit to the turn OFF delay of AUX7 is set. This setting is required to synchronize the ECU with the front and rear lights (FL/RL) with of the locomotive DCC decoder. The delay time is set in CV983.1 (turn ON delay) and CV984.1 (turn OFF delay). One unit corresponds to 8 milliseconds. The factory default value 50 equates to $50 \cdot 8 = 400$ milliseconds.

The outputs AUX12 and AUX13 cannot be used with the delay function if they are configured for electrical coupler operation.

4.3 Electrical Couplers (AUX12/13)

The special outputs dedicated for the usage of electrical couplers (AUX12/AUX13) are accessible to the user as solder pads (see 2.3). The setting for the specific use of these outputs is defined in CV982.0 (see Table 4.7). The operation of these outputs requires special settings, because the electrical coupler requires **higher power** for a shorter period when they are switched on, and a **lower power** for the hold time (if they are kept on). The power applied to the electrical couplers will depend on the duty cycle of the PWM signal applied.

The **switching on time** is set in CV1015.2, and the PWM signal value (intensity) is set in CV990.0 – front coupler or CV991.0 – rear coupler. These settings provide a proper switching-on operation for the electrical coupler.

In CV1016.2 the **hold-on time** is set with a PWM value of CV990.2 – front coupler and CV991.2 - rear coupler. The frequency of the PWM signal is approximately 20 kHz, ensuring a proper operation.

One time unit in CV1015.2 and CV1016.2 is equivalent to 40 milliseconds. So a value of 5 in CV1015.2 has the meaning of $5 * 40 = 200\text{ms}$, and the value of 75 in CV1016.2 equates to $75 * 40 = 3\text{ seconds}$. After the defined time in CV1016.2 elapses, the electrical coupler will be automatically switched off (even if the function which controls it is not released). A new coupler sequence will be initiated only after the controlling function is released and switched on again.

The ECU is controlling only the electrical coupler operation. For the control of the engine/locomotive movement in reverse/forward direction known as the specific "tango/waltzer" during the uncoupling, the locomotive decoder must be configured properly. To keep the electrical coupler engagement synchronized with the reverse/forward movement of the locomotive, both operations (the uncoupling controlled by the ECU and the movement of the locomotive controlled by the DCC decoder) must be mapped to the same function.

The front and rear electrical coupler outputs can be also used as standard outputs with PWM signal, with or without fade effect. The selection is made in CV902.0 Bit5 for AUX12 (front coupler) respectively Bit6 for AUX13 (rear coupler). For zero value of the Bit5 (Bit6) the outputs will behave as standard outputs. If the bits are set (1), the output will be configured for electrical coupler operation. The two outputs can be configured independently. One of them can be configured as electrical coupler while the other can be configured as standard output.

4.4 SPP operation

The integrated power pack (SPP) is enabled only in digital DCC operation. It will operate only while is receiving valid SUSI packets from the Next18 decoder. During the CV operations the SPP will be disabled if the Next18 decoder is transmitting the All Off command over the SUSI interface.

The SPP switching off time after the track contacts are lost can be set in CV1017.2. One unit of CV1017.2 is equivalent to 16 milliseconds. The default value of 62 is approximately equal to 1 second ($62 \cdot 16 = 992$ milliseconds). The highest value is approximately 4 seconds.

4.5 DC operation

In analog DC mode the ECU is not working. When an analog DC Dummy board is used instead a DCC decoder, only the standard light functions will operate (front and rear white/red), all other configurations will be disabled. If a Next18 DCC decoder is used with the ECU in analog DC mode, the active functions will depend on the DCC decoder configuration.

4.6 Short circuit protection

The outputs AUX12, AUX13 and AUX14 are user accesible as solder pads. They are short circuit protected power outputs. The short circuit current value is set in CV1019.2 with a factory default value of 63, which equivalets to a current limit of 500 mA (total current on the outputs). The current value calculation can be made with the following formula: $CV1019.2 = 126 \cdot I[A]$. Increasing this value above the factory default value is recommended only if the external consumer(s) requires a higher startup current. We strongly recommend to not alter the factory default value.

If the short circuit protection is triggered, this will be signaled in CV1018.2, which will be set to the value 1 (in normal condition, without errors, the value of the CV1018.2 is 0). Reading the value of CV1018.2 will inform us if there was a short circuit condition. The value of CV1018.2 will not be cleared automatically to 0, it must be done manually

The outputs which are used internally do not have short circuit protection.

4.7 CV table

In the table on the following pages are listed all the CV's of the ECU. The CV's are divided into 3 columns, one for each slave address (see also: Introduction Chapter 4). The CV's relevant to you are marked in bold.

CV			Factory Default CV-values	CV Valuee-Bereich	Description																																								
Slave1	Slave2	Slave3																																											
897			3	0-3	SUSI Slave Adresse																																								
898			0	/	reserved																																								
899			0	/	reserved																																								
900.0	940.0	980.0	78	0-255	Manufacturer ID/RESET 78=train-O-matic, any written value will reset the decor to the factory default CV values																																								
900.1	940.1	980.1	9	/	tOm Hardware ID																																								
900.2	940.2	980.2	1	/	TILLIG Hardware Version																																								
900.3	940.3	980.3	1	/	TILLIG Software Version																																								
900.254	940.254	980.254	0	/	Alternative Manufacturer ID																																								
901.0	941.0	981.0	3	/	Firmware Version																																								
901.1	941.1	981.1	6	/	Firmware Sub Version																																								
901.2	941.2	981.2	0	/	Firmware build number MSB																																								
901.3	941.3	981.3	159	/	Firmware build number LSB																																								
901.254	941.254	981.254	10	/	SUSI Version 1.0																																								
902.0	942.0	982.0	104 = 8 +32 +64	0-255	- Configuration Data: <table border="1" style="width: 100%; border-collapse: collapse;"> <tr> <td>Bit 0</td> <td>0</td> <td>(0)</td> <td>Normal driving direction</td> </tr> <tr> <td>=</td> <td>1</td> <td>(1)</td> <td>Inverted direction</td> </tr> <tr> <td>Bit 1</td> <td>0</td> <td>(0)</td> <td>SUSI-direction used</td> </tr> <tr> <td>=</td> <td>1</td> <td>(2)</td> <td>FL/RL-direction used</td> </tr> <tr> <td>Bit 3</td> <td>0</td> <td>(0)</td> <td>Aspect priority level used (1-8)</td> </tr> <tr> <td>=</td> <td>1</td> <td>(8)</td> <td>Aspect priority level not used</td> </tr> <tr> <td>Bit 5</td> <td>0</td> <td>(0)</td> <td>AUX12 Standard PWM output</td> </tr> <tr> <td>=</td> <td>1</td> <td>(32)</td> <td>AUX12 Output for electrical coupling</td> </tr> <tr> <td>Bit 6</td> <td>0</td> <td>(0)</td> <td>AUX13 Standard PWM output</td> </tr> <tr> <td>=</td> <td>1</td> <td>(64)</td> <td>AUX13 Output for electrical coupling</td> </tr> </table>	Bit 0	0	(0)	Normal driving direction	=	1	(1)	Inverted direction	Bit 1	0	(0)	SUSI-direction used	=	1	(2)	FL/RL-direction used	Bit 3	0	(0)	Aspect priority level used (1-8)	=	1	(8)	Aspect priority level not used	Bit 5	0	(0)	AUX12 Standard PWM output	=	1	(32)	AUX12 Output for electrical coupling	Bit 6	0	(0)	AUX13 Standard PWM output	=	1	(64)	AUX13 Output for electrical coupling
Bit 0	0	(0)	Normal driving direction																																										
=	1	(1)	Inverted direction																																										
Bit 1	0	(0)	SUSI-direction used																																										
=	1	(2)	FL/RL-direction used																																										
Bit 3	0	(0)	Aspect priority level used (1-8)																																										
=	1	(8)	Aspect priority level not used																																										
Bit 5	0	(0)	AUX12 Standard PWM output																																										
=	1	(32)	AUX12 Output for electrical coupling																																										
Bit 6	0	(0)	AUX13 Standard PWM output																																										
=	1	(64)	AUX13 Output for electrical coupling																																										
902.1	942.1	982.1	0	0-1	reserved																																								
902.2	942.2	982.2	0	0-1	standard or extended function mapping																																								
902.3	942.3	982.3	0	0-255	Lock Value																																								
903.0	943.0	983.0	50	1-127	Time for Fade In Effect in 8ms Steps																																								
903.1	943.1	983.1	50	0-255	Time of Turn On Delay in 8ms Steps																																								
903.2	943.2	983.2	0	0-255	Outputs Turn On Delay (AUX7-14) bit0 – AUX7... bit7 – AUX14 (see 4.1.1) Bit Value = 0, instant Turn On Bit Value = 1, Turn On Delay is used																																								
903.3	943.3	983.3	1	0-255	Lock ID																																								

904.0	944.0	984.0	50	1-127	Time for Fade Out Effect in 8ms Steps
904.1	944.1	984.1	50	0-255	Time of Turn Off Delay in 8ms Steps
904.2	944.2	984.2	17		Outputs Turn Off Delay (AUX7-14) bit0 – AUX7... bit7 – AUX14 (see 4.1.1) Bit Value = 0, instant Turn Off Bit Value = 1, Turn Off Delay is used
905.0	945.0	985.0	255	/	AUX7 max. PWM Value (keep it at Value 255)
905.1	945.1	985.1	/	0-255	reserved (Turn On Delay electrical coupling)
905.2	945.2	985.2	0	0-255	Outputs Turn On Delay (AUX15) bit0 – AUX15 (see 4.1.1) Bit Value = 0, instant Turn On Bit Value = 1, Turn On Delay is used
906.0	946.0	986.0	255	0-255	AUX8 max. PWM Value (Light intensity)
906.2	946.2	986.2	1	0-255	Outputs Turn On Delay (AUX15) bit0 – AUX15 (see 4.1.1) Bit Value = 0, instant Turn Off Bit Value = 1, Turn Off Delay is used
907.0	947.0	987.0	255	0-255	max. PWM Value AUX9 (Light intensity)
908.0	948.0	988.0	255	0-255	max. PWM Value AUX10 (Light intensity)
909.0	949.0	989.0	255	/	max. PWM Value AUX11 (keep it at Value 255)
910.0	950.0	990.0	255	0-255	max. PWM Value AUX12 (Light intensity) or High-PWM Value front electrical coupling
910.2	950.2	990.2	100	0-255	Low-PWM Value front electrical coupling
911.0	951.0	991.0	255	0-255	max. PWM Value AUX13 (Light intensity) or High-PWM Value back electrical coupling
911.2	951.2	991.2	100	0-255	Low-PWM Value back electrical coupling
912.0	952.0	992.0	255	0-255	max. PWM Value AUX14 (Light intensity)
913.0	953.0	993.0	0	/	reserved
914.0	954.0	994.0	255	0-255	Outputs Fade Effect (AUX7-14) bit0 – AUX7... bit7 – AUX14 (see 4.1.1) Bit Value = 0, instant Turn On and Off Bit Value = 1, using Fade Effect
915.0	955.0	995.0	5	0-156	1. Function button which is mapped at Aspect 1
915.1	955.1	995.1	63	0-156	2. Function button which is mapped at Aspect 1
915.2	955.2	995.2	63	0-156	3. Function button which is mapped at Aspect 1
916.0	956.0	996.0	6	0-156	1. Function button which is mapped at Aspect 2
916.1	956.1	996.1	63	0-156	2. Function button which is mapped at Aspect 2
916.2	956.2	996.2	63	0-156	3. Function button which is mapped at Aspect 2
917.0	957.0	997.0	13	0-156	1. Function button which is mapped at Aspect 3
917.1	957.1	997.1	63	0-156	2. Function button which is mapped at Aspect 3
917.2	957.2	997.2	63	0-156	3. Function button which is mapped at Aspect 3
918.0	958.0	998.0	7	0-156	1. Function button which Aspect 4
918.1	958.1	998.1	63	0-156	2. Function button which is mapped at Aspect 4
918.2	958.2	998.2	63	0-156	3. Function button which is mapped at Aspect 4

919.0	959.0	999.0	4	0-156	1. Function button which is mapped at Aspect 5
919.1	959.1	999.1	63	0-156	2. Function button which is mapped at Aspect 5
919.2	959.2	999.2	63	0-156	3. Function button which is mapped at Aspect 5
920.0	960.0	1000.0	2	0-156	1. Function button which Aspect 6
920.1	960.1	1000.1	63	0-156	2. Function button which is mapped at Aspect 6
920.2	960.2	1000.2	63	0-156	3. Function button which is mapped at Aspect 6
921.0	961.0	1001.0	12	0-156	1. Function button which is mapped at Aspect 7
921.1	961.1	1001.1	63	0-156	2. Function button which is mapped at Aspect 7
921.2	961.2	1001.2	63	0-156	3. Function button which is mapped at Aspect 7
922.0	962.0	1002.0	14	0-156	1. Function button which is mapped at Aspect 8
922.1	962.1	1002.1	63	0-156	2. Function button which is mapped at Aspect 8
922.2	962.2	1002.2	63	0-156	3. Function button which is mapped at Aspect 8
923.0	963.0	1003.0	0	-	reserved
924.0	964.0	1004.0	4	0-255	Output Aspect 1 (AUX7-14), forward (see 4.1.1)
924.1	964.1	1004.1	0	0-255	Output Aspect 1 (AUX15), forward (see 4.1.1)
925.0	965.0	1005.0	4	0-255	Output Aspect 1 (AUX7-14), backward (see 4.1.1)
925.1	965.1	1005.1	0	0-255	Output Aspect 1 (AUX15), backward (see 4.1.1)
926.0	966.0	1006.0	8	0-255	Output Aspect 2 (AUX7-14), forward (see 4.1.1)
926.1	966.1	1006.1	0	0-255	Output Aspect 2 (AUX15), forward (see 4.1.1)
927.0	967.0	1007.0	8	0-255	Output Aspect 2 (AUX7-14), backward (see 4.1.1)
927.1	967.1	1007.1	0	0-255	Output Aspect 2 (AUX15), backward (see 4.1.1)
928.0	968.0	1008.0	128	0-255	Output Aspect 3 (AUX7-14), forward (see 4.1.1)
928.1	968.1	1008.1	0	0-255	Output Aspect 3 (AUX15), forward (see 4.1.1)
929.0	969.0	1009.0	128	0-255	Output Aspect 3 (AUX7-14), backward (see 4.1.1)
929.1	969.1	1009.1	0	0-255	Output Aspect 3 (AUX15), backward (see 4.1.1)
930.0	970.0	1010.0	16	0-255	Output Aspect 4 (AUX7-14), forward (see 4.1.1)
930.1	970.1	1010.1	0	0-255	Output Aspect 4 (AUX15), forward (see 4.1.1)
931.0	971.0	1011.0	16	0-255	Output Aspect 4 (AUX7-14), backward (see 4.1.1)
931.1	971.1	1011.1	0	0-255	Output Aspect 4 (AUX15), backward (see 4.1.1)
932.0	972.0	1012.0	2	0-255	Output Aspect 5 (AUX7-14), forward (see 4.1.1)
932.1	972.1	1012.1	0	0-255	Output Aspect 5 (AUX15), forward (see 4.1.1)

933.0	973.0	1013.0	2	0-255	Output Aspect 5 (AUX7-14), backward (see 4.1.1)
933.1	973.1	1013.1	0	0-255	Output Aspect 5 (AUX15), backward (see 4.1.1)
934.0	974.0	1014.0	1	0-255	Output Aspect 6 (AUX7-14), forward (see 4.1.1)
934.1	974.1	1014.1	0	0-255	Output Aspect 6 (AUX15), forward (see 4.1.1)
935.0	975.0	1015.0	1	0-255	Output Aspect 6 (AUX7-14), backward (see 4.1.1)
935.1	975.1	1015.1	0	0-255	Output Aspect 6 (AUX15), backward (see 4.1.1)
935.2	975.2	1015.2	5	0-255	Time for high PWM of electrical coupling in 40ms Steps
936.0	976.0	1016.0	64	0-255	Output Aspect 7 (AUX7-14), forward (see 4.1.1)
936.1	976.1	1016.1	0	0-255	Output Aspect 7 (AUX15), forward (see 4.1.1)
936.2	976.2	1016.2	75	0-255	Time for low PWM of electrical coupling in 40ms Steps
937.0	977.0	1017.0	32	0-255	Output Aspect 7 (AUX7-14), backward (see 4.1.1)
937.1	977.1	1017.1	0	0-255	Output Aspect 7 (AUX15), backward (see 4.1.1)
937.2	977.2	1017.2	255	0-255	Buffering time SPP turn off delay, after losing track power
938.0	978.0	1018.0	0	0-255	Output Aspect 8 (AUX7-14), forward (see 4.1.1)
938.1	978.1	1018.1	1	0-255	Output Aspect 8 (AUX15), forward (see 4.1.1)
938.2	978.2	1018.2	0-1	0	Output short circuit flag
939.0	979.0	1019.0	0	0-255	Output Aspect 8 (AUX7-14), backward (see 4.1.1)
939.1	979.1	1019.1	1	0-255	Output Aspect 8 (AUX15), backward (see 4.1.1)
939.2	979.2	1019.2	63	0-255	Outputs short circuit protection level
	1020		/	/	SUSI Status Byte
	1021		3	0-254	CV memory-Bank selector
	1022		/	/	reserved
	1023		/	/	reserved
	1024		/	/	reserved